

## Xtratherm Ltd

Liscarton Industrial Estate  
Kells Road  
Navan  
Co Meath  
Ireland  
Tel: 0371 2221033 Fax: 0371 2221044  
e-mail: info@xtratherm.com  
website: www.xtratherm.com



## Agrément Certificate

10/4786

Product Sheet 1

### XTRATHERM CAVITY WALL INSULATION

### XTRATHERM CAVITY THERM

This Agrément Certificate Product Sheet<sup>(1)</sup> relates to Xtratherm Cavity Therm, comprising a rigid polyisocyanurate (PIR) board faced with a composite foil-facing on both sides, bonded to profiled high impact polystyrene (HIP) on the exposed face. The product is for use as full fill thermal insulation in new external masonry cavity walls up to 25 metres in height in domestic and non-domestic buildings (additional requirements apply for buildings above 12 metres). The product is installed during construction.

(1) Hereinafter referred to as 'Certificate'.

#### CERTIFICATION INCLUDES:

- factors relating to compliance with Building Regulations where applicable
- factors relating to additional non-regulatory information where applicable
- independently verified technical specification
- assessment criteria and technical investigations
- design considerations
- installation guidance
- regular surveillance of production
- formal three-yearly review.

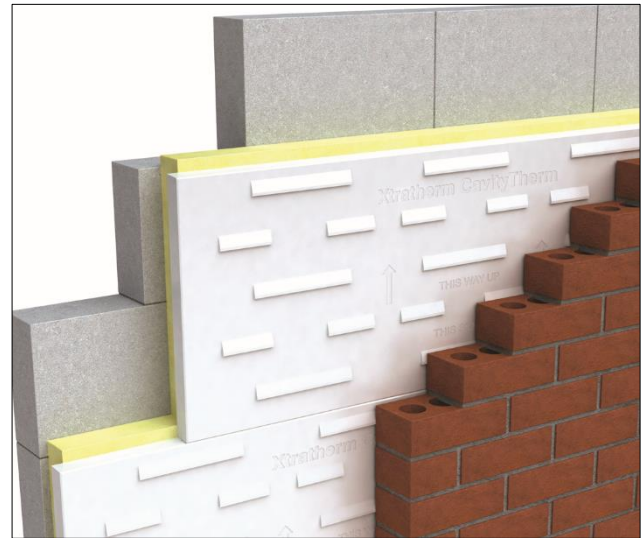

#### KEY FACTORS ASSESSED

**Thermal performance** — the product has a declared thermal conductivity ( $\lambda_D$ ) of  $0.021 \text{ W}\cdot\text{m}^{-1}\cdot\text{K}^{-1}$  (see section 6).

**Water resistance** — the product will resist the transfer of water across the cavity (see section 7).

**Condensation risk** — the product will contribute to limiting the risk of condensation (see section 8).

**Behaviour in relation to fire** — the Certificate holder has not declared a reaction to fire classification to BS EN 13501-1 : 2018 (see section 9).

**Durability** — the product is durable, rot proof, water resistant and sufficiently stable to remain effective as insulation for the life of the building (see section 12).

The BBA has awarded this Certificate to the company named above for the product described herein. This product has been assessed by the BBA as being fit for its intended use provided it is installed, used and maintained as set out in this Certificate.

On behalf of the British Board of Agrément

Date of Fourth issue: 3 May 2017

John Albon – Head of Approvals  
Construction Products

Originally certificated on 1 October 2010

Certificate amended on 21 March 2019 to include Regulation 7(2) for England and associated text.

Claire Curtis-Thomas  
Chief Executive

*The BBA is a UKAS accredited certification body – Number 113.*

*The schedule of the current scope of accreditation for product certification is available in pdf format via the UKAS link on the BBA website at [www.bbacerts.co.uk](http://www.bbacerts.co.uk)  
Readers are advised to check the validity and latest issue number of this Agrément Certificate by either referring to the BBA website or contacting the BBA direct.*

*Any photographs are for illustrative purposes only, do not constitute advice and should not be relied upon.*

#### British Board of Agrément

Bucknalls Lane  
Watford  
Herts WD25 9BA

©2017

tel: 01923 665300  
[clientservices@bbacerts.co.uk](mailto:clientservices@bbacerts.co.uk)  
[www.bbacerts.co.uk](http://www.bbacerts.co.uk)

## Regulations

In the opinion of the BBA, Xtratherm Cavity Therm, if installed, used and maintained in accordance with this Certificate, can satisfy or contribute to satisfying the relevant requirements of the following Building Regulations (the presence of a UK map indicates that the subject is related to the Building Regulations in the region or regions of the UK depicted):



### The Building Regulations 2010 (England and Wales) (as amended)

<b>Requirement:</b>	<b>B3(4)</b>	<b>Internal fire spread (structure)</b>
Comment:		The product is restricted by this Requirement. See sections 9.2, 9.3 and 9.5 of this Certificate.
<b>Requirement:</b>	<b>C2(a)</b>	<b>Resistance to moisture</b>
Comment:		The product can contribute to satisfying this Requirement. See section 7.1 of this Certificate.
<b>Requirement:</b>	<b>C2(b)</b>	<b>Resistance to moisture</b>
Comment:		The product can contribute to satisfying this Requirement. See section 7.2 of this Certificate.
<b>Requirement:</b>	<b>C2(c)</b>	<b>Resistance to moisture</b>
Comment:		The product can contribute to satisfying this Requirement. See sections 8.1 and 8.4 of this Certificate.
<b>Requirement:</b>	<b>L1(a)(i)</b>	<b>Conservation of fuel and power</b>
Comment:		The product can contribute to satisfying this Requirement. See section 6 of this Certificate.
<b>Regulation:</b>	<b>7</b>	<b>Materials and Workmanship (applicable to Wales only)</b>
<b>Regulation:</b>	<b>7(1)</b>	<b>Materials and Workmanship (applicable to England only)</b>
Comment:		The product is acceptable. See section 12 and the <i>Installation</i> part of this Certificate.
<b>Regulation:</b>	<b>7(2)</b>	<b>Materials and Workmanship (applicable to England only)</b>
Comment:		The product is restricted by this Regulation. See sections 9.2, 9.3 and 9.5 of this Certificate.
<b>Regulation:</b>	<b>26</b>	<b>CO<sub>2</sub> emission rates for new buildings</b>
<b>Regulation:</b>	<b>26A</b>	<b>Fabric energy efficiency rates for new dwellings (applicable to England only)</b>
<b>Regulation:</b>	<b>26A</b>	<b>Primary energy consumption rates for new buildings (applicable to Wales only)</b>
<b>Regulation:</b>	<b>26B</b>	<b>Fabric performance values for new dwellings (applicable to Wales only)</b>
Comment:		The product can contribute to satisfying these Regulations but compensating fabric/services measures may need to be taken. See section 6 of this Certificate.



### The Building (Scotland) Regulations 2004 (as amended)

<b>Regulation:</b>	<b>8(1)</b>	<b>Durability, workmanship and fitness of materials</b>
Comment:		The product can contribute to a construction satisfying this Regulation. See section 12 and the <i>Installation</i> part of this Certificate.
<b>Regulation:</b>	<b>9</b>	<b>Building standards applicable to construction</b>
Standard:	<b>2.6</b>	Spread to neighbouring buildings
Comment:		The product is restricted by this Standard with respect to clauses 2.6.5 <sup>(1)</sup> and 2.6.6 <sup>(2)</sup> . See sections 9.4 and 9.5 of this Certificate.
Standard:	<b>2.7</b>	Spread on external walls
Comment:		The product is restricted by this Standard with respect to clause 2.7.2 <sup>(2)</sup> . See sections 9.4 and 9.5 of this Certificate.
Standard:	<b>3.4</b>	Moisture from the ground
Comment:		The product can contribute to a construction satisfying this Standard, with reference to clause 3.4.1 <sup>(1)(2)</sup> . See section 7.1 of this Certificate.

Standard:	3.10	Precipitation
Comment:		The product can contribute to satisfying this Standard, with reference to clause 3.10.1 <sup>(1)(2)</sup> , provided it complies with the conditions set out in section 7.2 of this Certificate.
Standard:	3.15	Condensation
Comment:		The product can contribute to satisfying this Standard, with reference to clauses 3.15.1 <sup>(1)(2)</sup> , 3.15.4 <sup>(1)(2)</sup> and 3.15.5 <sup>(1)(2)</sup> . See sections 8.1 and 8.5 of this Certificate.
Standard:	6.1(b)	Carbon dioxide emissions
Standard:	6.2	Building insulation envelope
Comment:		This product can contribute to satisfying clauses, or parts of, 6.1.1 <sup>(1)</sup> , 6.1.2 <sup>(2)</sup> , 6.1.6 <sup>(1)</sup> , 6.2.1 <sup>(1)(2)</sup> , 6.2.3 <sup>(1)</sup> , 6.2.4 <sup>(2)</sup> , 6.2.5 <sup>(2)</sup> , 6.2.9 <sup>(1)</sup> and 6.2.11 <sup>(2)</sup> of these Standards. See section 6 of this Certificate.
Standard:	7.1(a)(b)	Statement of sustainability
Comment:		The product can contribute to satisfying the relevant requirements of Regulation 9, Standards 1 to 6, and therefore will contribute to a construction meeting a bronze level of sustainability as defined in this Standard. In addition, the product can contribute to a construction meeting a higher level of sustainability as defined in this Standard, with reference to clauses 7.1.4 <sup>(1)(2)</sup> [Aspects 1 <sup>(1)(2)</sup> and 2 <sup>(1)</sup> ], 7.1.6 <sup>(1)(2)</sup> [Aspects 1 <sup>(1)(2)</sup> and 2 <sup>(1)</sup> ] and 7.1.7 <sup>(1)(2)</sup> [Aspect 1 <sup>(1)(2)</sup> ]. See section 6 of this Certificate.
<b>Regulation:</b>	<b>12</b>	<b>Building standards applicable to conversions</b>
Comment:		All comments given for this product under Regulation 9, Standards 1 to 6, also apply to this Regulation, with reference to clause 0.12.1 <sup>(1)(2)</sup> and Schedule 6 <sup>(1)(2)</sup> .

(1) Technical Handbook (Domestic)  
(2) Technical Handbook (Non-Domestic).



## The Building Regulations (Northern Ireland) 2012 (as amended)

<b>Regulation:</b>	<b>23</b>	<b>Fitness of materials and workmanship</b>
Comment:		The product is an acceptable material. See section 12 and the <i>Installation</i> part of this Certificate.
<b>Regulation:</b>	<b>28(a)</b>	<b>Resistance to moisture and weather</b>
Comment:		The product can contribute to a construction satisfying this Regulation. See section 7.1 of this Certificate.
<b>Regulation:</b>	<b>28(b)</b>	<b>Resistance to moisture and weather</b>
Comment:		The product can contribute to satisfying this Regulation. See section 7.2 of this Certificate.
<b>Regulation:</b>	<b>29</b>	<b>Condensation</b>
Comment:		The product can contribute to satisfying this Regulation. See section 8.1 of this Certificate.
<b>Regulation:</b>	<b>35(4)</b>	<b>Internal fire spread — structure</b>
Comment:		The product is restricted by this Regulation. See sections 9.3 and 9.5 of this Certificate.
<b>Regulation:</b>	<b>39(a)(i)</b>	<b>Conservation measures</b>
<b>Regulation:</b>	<b>40(2)</b>	<b>Target carbon dioxide emission rate</b>
Comment:		The product can contribute to satisfying these Regulations. See section 6 of this Certificate.

## Construction (Design and Management) Regulations 2015

## Construction (Design and Management) Regulations (Northern Ireland) 2007

Information in this Certificate may assist the client, designer (including Principal Designer) and contractor (including Principal Contractor) to address their obligations under these Regulations.

See section: *3 Delivery and site handling* (3.4) of this Certificate.

## Additional Information

### NHBC Standards 2017

NHBC accepts the use of Xtratherm Cavity Therm, other than in very severe exposure locations with fair-faced masonry, provided it is installed, used and maintained in accordance with this Certificate, in relation to *NHBC Standards*, Chapter 6.1 *External masonry walls*.

### CE marking

The Certificate holder has taken the responsibility of CE marking the product in accordance with harmonised European Standard BS EN 13165 : 2012. An asterisk (\*) appearing in this Certificate indicates that data shown are given in the manufacturer's Declaration of Performance.

## Technical Specification

### 1 Description

1.1 Xtratherm Cavity Therm comprises rigid polyisocyanurate (PIR) board, faced with a composite foil-facing on both sides, bonded to profiled high impact polystyrene (HIP) on the exposed face.

1.2 The product has the nominal characteristics shown in Table 1.

*Table 1 Nominal characteristics*

Length x width (mm)	1185 x 450
Thickness <sup>(1)</sup> (mm)	75, 90, 100, 125, 150
Edge detail	Rebated

(1) Includes projecting tapered flute (flute = 0.5 mm thick and 5 mm deep) (see Figure 1).

1.3 Each board incorporates a rebated edging on all four sides, enabling the boards to interlock when installed.

1.4 The external face of the board incorporates a vacuum-formed HIP sheet with tapered flutes to provide a drainage plane and shed water away from the internal leaf, and to act as a guide to the construction of the outer leaf. Each board is marked to identify the correct orientation for installation (see Figure 1).

Figure 1 Xtratherm Cavity Therm (all dimensions in mm)

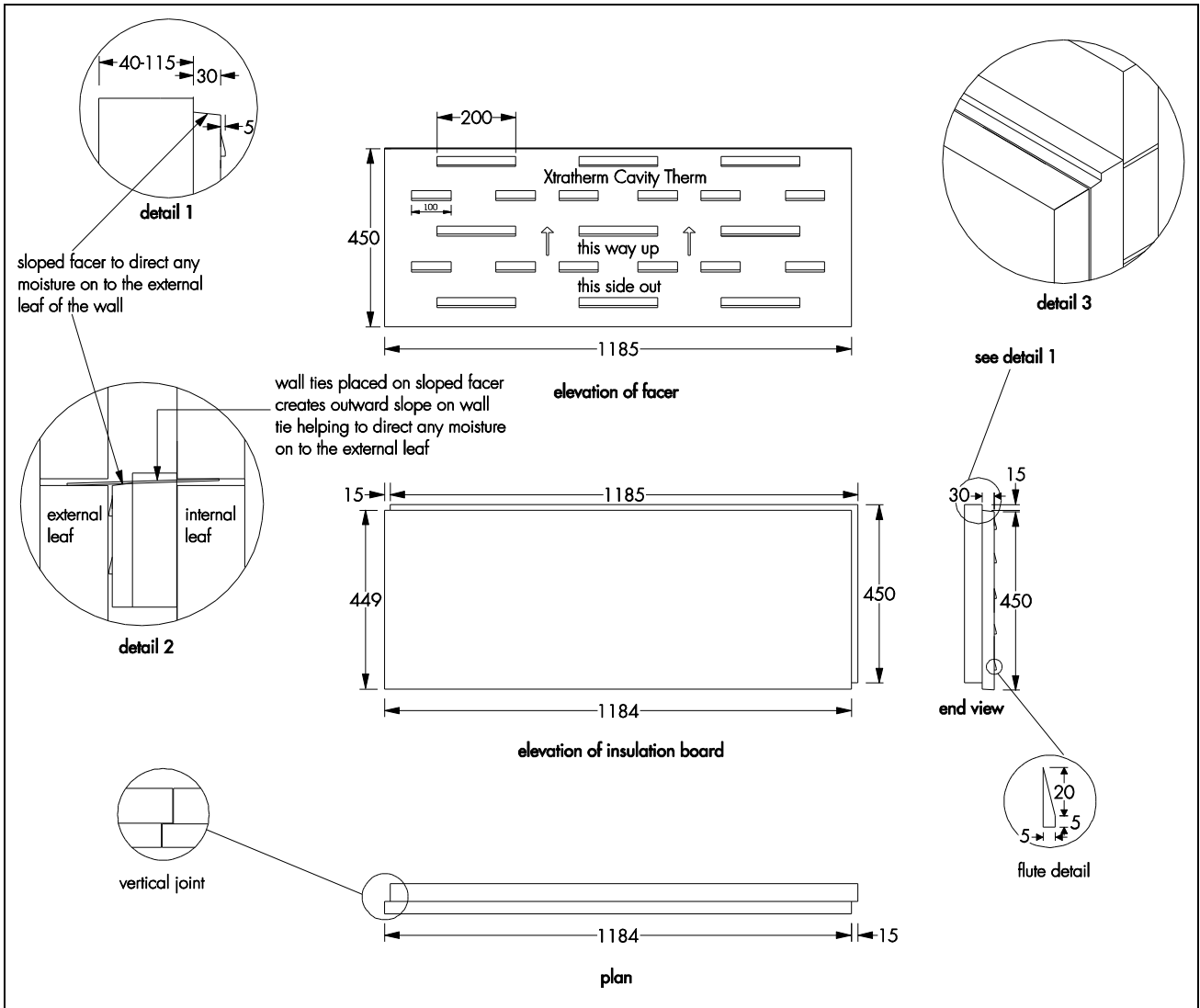

1.5 The following variations of Xtratherm Cavity Therm (see Figure 2) are used to aid installation and are included in the scope of this Certificate:

- Preformed Corner Panels — a preformed panel of Cavity Therm (1185 mm x 450 mm) that folds to provide a perfect 90° corner, either external or internal
- Riser Panels — a Cavity Therm half-board (1185 mm x 225 mm) that is positioned below the damp proof course (dpc) at floor levels and allows for the recommended overlap between wall and floor insulation
- Top Panels — a Cavity Therm half-board (1185 mm x 225 mm) that is used to finish wall insulation heights when a full board is not required.

Figure 2 Xtratherm Cavity Therm accessories

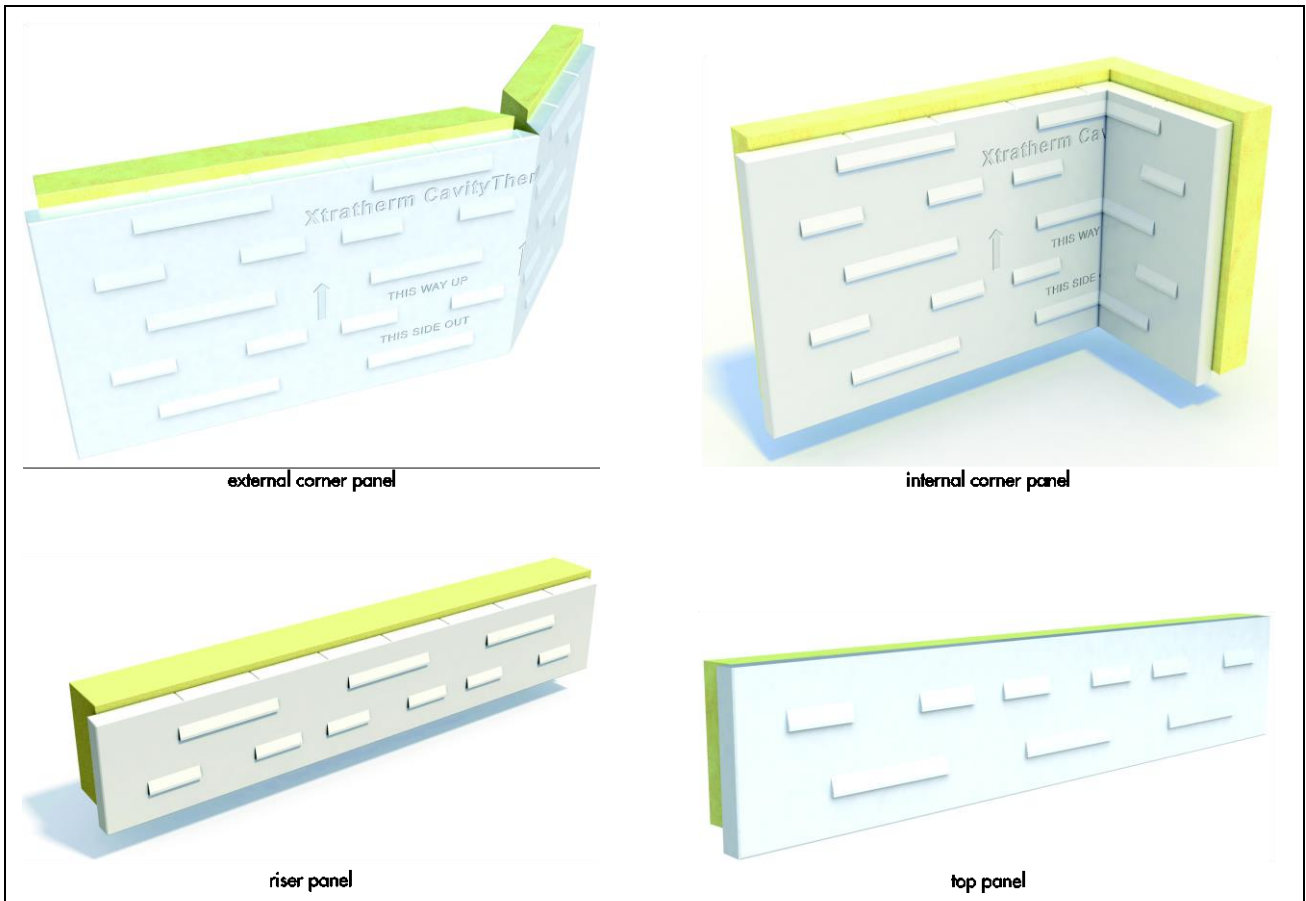

1.6 Other accessories<sup>(1)</sup> which may be used with Xtratherm Cavity Therm, but which are outside the scope of this Certificate, include:

- Insulated Cavity Tray Channel — an insulated channel to allow for insulation continuity around stepped cavity trays at gable junctions
- Service Void Panels — a preformed panel that creates an insulated service void for periscopic floor vents in suspended floor situations
- Meter Box Panels — a preformed meter box accessory which allows a recess space for placement of a meter box, leaving the insulation to run in a continuous plane
- Jointing Strip — for the protection of board joints
- Hockey Stick Insulation — allows for easy access to the cable that supplies the meter box and is preformed to fit the insulation.

(1) Contact the Certificate holder for further details.

## 2 Manufacture

2.1 Raw materials, mixed to a controlled formulation, are blended and poured onto the foil-facing then cured and cut to the required dimensions. A thermo-formed HIP sheet is then adhered to the board.

2.2 As part of the assessment and ongoing surveillance of product quality, the BBA has:

- agreed with the manufacturer the quality control procedures and product testing to be undertaken
- assessed and agreed the quality control operated over batches of incoming materials
- monitored the production process and verified that it is in accordance with the documented process
- evaluated the process for management of nonconformities
- checked that equipment has been properly tested and calibrated
- undertaken to carry out the above measures on a regular basis through a surveillance process, to verify that the specifications and quality control operated by the manufacturer are being maintained.

2.3 The management systems of Xtratherm Ltd has been assessed and registered as meeting the requirements of BS EN ISO 9001 : 2008 and BS EN ISO 14001 : 2004 by the LPCB (Certificates 851 and 851-EMS respectively).

### 3 Delivery and site handling

3.1 The boards are delivered to site in polythene-wrapped packs. Each pack contains a label bearing the manufacturer's name, board dimensions and the BBA logo incorporating the number of this Certificate.

3.2 The boards must be protected from prolonged exposure to sunlight, and stored dry, flat and raised above ground level (to avoid contact with ground moisture). Where possible, packs should be stored inside. If stored outside, they should be under cover, or protected with opaque polythene sheeting.

3.3 The boards are light and easy to handle; care should be exercised to avoid crushing the edges or corners. If damaged, the product should be discarded.

3.4 The boards must not be exposed to open flame or other ignition sources, or to solvents or other chemicals.

## Assessment and Technical Investigations

The following is a summary of the assessment and technical investigations carried out on Xtratherm Cavity Therm.

## Design Considerations

### 4 Use

4.1 Xtratherm CavityFill is satisfactory for use as a full fill cavity wall insulation and is effective in reducing the thermal transmittance (U value) of external cavity walls with masonry inner and outer leaves (where masonry includes clay and calcium silicate bricks, concrete blocks, and natural and reconstituted stone blocks). The product is for use in new domestic and non-domestic buildings up to and including 25 metres in height. It is essential that such walls are designed and constructed to incorporate the precautions given in this Certificate to prevent moisture penetration.

4.2 This Certificate covers the use of the product in any exposure zone. However, use of the product does not preclude the need to apply any external render coat or other suitable finish in severe exposure zones where such application would be normal practice.

4.3 As with other forms of cavity wall insulation, where buildings need to comply with *NHBC Standards 2017*, specifiers should observe the requirements of that document.

4.4 New buildings subject to the national Building Regulations should be constructed in accordance with the relevant recommendations of:

- BS EN 1996-1-1 : 2005, BS EN 1996-1-2 : 2005, BS EN 1996-2 : 2006 and BS EN 1996-3 : 2006 and their respective UK National Annexes
- BS EN 845-1 : 2013 and BS 8000-3 : 2001.

4.5 New buildings not subject to regulatory requirements should also be built in accordance with the Standards identified in section 4.4 of this Certificate.

4.6 Cavity wall ties and, if required, any additional ties to BS EN 845-1 : 2013 and PD 6697 : 2010 should be used for structural stability in accordance with BS EN 1996-1-1 : 2005, BS EN 1996-2 : 2006 and BS EN 1996-3 : 2006.

4.7 Care must be taken in the overall design and construction of walls incorporating the product to ensure the provision of appropriate:

- cavity trays and damp-proof courses (dpc's)
- cavity barriers and fire dampers
- resistance to the ingress of precipitation, moisture and dangerous gases from the ground
- resistance to sound transmission when flanking separating walls and floors.

## Buildings over 12 metres high and up to and including 25 metres high

4.8 Where the walls of a building are between 12 metres and 25 metres high, the following requirements also apply:

- from ground level, the maximum height of continuous cavity must not exceed 12 metres. Above 12 metres, the maximum height of a continuous cavity must not exceed 7 metres. In both cases, breaks should be in the form of continuous horizontal cavity trays and weep holes discharging to the outside
- the area to be insulated must not be an infill panel in a framed structure
- the Certificate holder, in association with the architect, must carry out a detailed programme of assessment of the project, including an examination of the quality of installation as work progresses. Above average site supervision is recommended during installation.

## 5 Practicability of installation

The product is designed to be installed by a competent general builder, or a contractor, experienced with this type of product.

## 6 Thermal performance



6.1 Calculations of the thermal transmittance (U value) of specific external wall constructions should be carried out in accordance with BS EN ISO 6946 : 2007 and BRE Report BR 443 : 2006, using the insulation's declared thermal conductivity ( $\lambda_D$ )\* of  $0.021 \text{ W}\cdot\text{m}^{-1}\cdot\text{K}^{-1}$ .

6.2 The U value of a completed wall will depend on the insulation thickness, number and type of fixings, the insulating value of the substrate masonry and its internal finish. Calculated U values for example constructions are given in Table 2.

Table 2 Example U values<sup>(1)(2)</sup> — new buildings

U value requirement ( $\text{W}\cdot\text{m}^{-2}\cdot\text{K}^{-1}$ )	Insulation thickness (mm)	
	13 mm dense plaster <sup>(3)</sup> 100 mm dense block <sup>(4)</sup>	Plasterboard on dabs 100 mm AAC block <sup>(5)</sup>
0.12	—	150
0.13	150	150
0.14	150	125
0.16	125	125
0.17	125	100
0.18	125	90
0.19	100	90
0.25	75	75
0.26	75	75
0.27	75	75
0.28	75	75
0.30	75	75
0.35	75	75

(1) Assumes fixings correction for fully-penetrating stainless steel fixings ( $17 \text{ W}\cdot\text{m}^{-1}\cdot\text{K}^{-1}$ ) at  $2.5 \text{ per m}^2$  with a cross-sectional area of  $12.5 \text{ mm}^2$ , nominal U value and 102 mm thick brick outer leaf.

(2) 5 mm residual cavity assumed fully filled with mortar squeeze,  $\lambda = 0.94 \text{ W}\cdot\text{m}^{-1}\cdot\text{K}^{-1}$ .

(3) Plaster thermal conductivity of  $0.57 \text{ W}\cdot\text{m}^{-1}\cdot\text{K}^{-1}$ .

(4) Block and mortar thermal conductivity of  $1.13 \text{ W}\cdot\text{m}^{-1}\cdot\text{K}^{-1}$  and  $0.88 \text{ W}\cdot\text{m}^{-1}\cdot\text{K}^{-1}$  respectively.

(5) Block and mortar thermal conductivity of  $0.12 \text{ W}\cdot\text{m}^{-1}\cdot\text{K}^{-1}$  and  $0.88 \text{ W}\cdot\text{m}^{-1}\cdot\text{K}^{-1}$  respectively.



## Junctions



6.3 Care must be taken in the overall design and construction of junctions with other elements and openings to minimise thermal bridges and air infiltration. Detailed guidance can be found in the documents supporting the national Building Regulations. Advice can also be sought from the Certificate holder.

## 7 Water resistance



7.1 The product can be used in situations where it bridges the dpc in walls; dampness from the ground will not pass through to the inner leaf provided the wall is detailed in accordance with the requirements and provisions of the national Building Regulations.

7.2 Constructions incorporating the product and built in accordance with the Standards listed in section 4.4, will resist the transfer of precipitation to the inner leaf and satisfy the requirements of the national Building Regulations.

7.3 In all situations, it is particularly important to ensure that:

- installation is carried out to the highest level on each wall, or the top edge of the insulation is protected by a cavity tray
- cavity trays are used with appropriate stop ends and weep holes at lintel level
- cavity battens and/or boards are used during construction, to prevent bridging by mortar droppings
- wall ties are installed correctly and are thoroughly clean
- excess mortar is cleaned from the cavity face of the leading leaf and any debris removed from the cavity
- mortar droppings are cleaned from the exposed edges of installed boards
- dpc's at ground level do not project into the cavity as they can form a trap for mortar bridging
- insulation boards are properly installed and butt-jointed
- raked or recessed mortar joints are avoided in very severe exposure areas.

7.4 Window and door opening reveals should be constructed incorporating a cavity barrier/closer/dpc, as required (see sections 13 and 14).

7.5 Where the Preformed Corner Panels are not used, wall corners are to be constructed incorporating a vertical dpc as noted in section 14.17 of this Certificate.

## 8 Condensation risk

### Interstitial condensation



8.1 Walls will adequately limit the risk of interstitial condensation when they are designed and constructed in accordance with BS 5250 : 2011, Annexes D and G and the relevant guidance.

8.2 For the purposes of calculations, the vapour resistivity/resistance value of the individual components may be taken as:

- polyisocyanurate insulation —  $300 \text{ MN}\cdot\text{s}\cdot\text{g}^{-1}\cdot\text{m}^{-1}$
- foil-facing —  $7000 \text{ MN}\cdot\text{s}\cdot\text{g}^{-1}$
- HIP facing —  $110 \text{ MN}\cdot\text{s}\cdot\text{g}^{-1}$ .

8.3 If the product is to be used in the external wall of rooms expected to have high humidity, care must be taken to provide adequate permanent ventilation to avoid possible problems from the formation of interstitial condensation in the internal wall leaf.

## Surface condensation



8.4 Walls will adequately limit the risk of surface condensation when the thermal transmittance (U value) does not exceed  $0.7 \text{ W}\cdot\text{m}^{-2}\cdot\text{K}^{-1}$  at any point and the junctions with other elements are designed in accordance with the guidance referred to in section 6.3 of this Certificate.



8.5 For buildings in Scotland, constructions will be acceptable where the thermal transmittance (U value) does not exceed  $1.2 \text{ W}\cdot\text{m}^{-2}\cdot\text{K}^{-1}$  at any point and the junctions with other elements are designed in accordance with the guidance referred to in BS 5250 : 2011, Annex G. Further guidance may be obtained from BRE Report BR 262 : 2002 and section 6.3 of this Certificate.

## 9 Behaviour in relation to fire

9.1 The Certificate holder has not declared a reaction to fire classification to BS EN 13501-1 : 2018.



9.2 In England, the product should not be used on buildings with a storey 18 m or more above ground level that contains; one or more dwellings, an institution, a room for residential purposes (excluding any room in a hostel, hotel or boarding house), student accommodation, care homes, sheltered housing, hospitals or dormitories in boarding schools.



9.3 In England for constructions not covered by section 9.2, and for constructions in Wales and Northern Ireland, the product is not classified as being of limited combustibility but the requirements of the national Building Regulations relating to fire spread in cavity walls can be satisfied in buildings of all-purpose groups without the need for cavity barriers, or restrictions on height or proximity to boundaries, provided the construction complies with the relevant provisions detailed in:

**England and Wales** — Approved Document B, Volume 1, Diagram 13, or Volume 2, Diagram 34

**Northern Ireland** — Technical Booklet E, Diagram 4.5.



9.4 In Scotland, the product is not classified as non-combustible but may be used without height restriction in a wall on, or less than 1 m from, a relevant boundary, provided it is installed in a cavity that is between two leaves of masonry at least 75 mm thick, and which has a cavity barrier around all openings in the wall and at the top of the wall head.



9.5 For constructions not covered by sections 9.3 or 9.4, the use of the product is restricted to buildings with no floor more than 18 m above the ground and cavity barriers must be provided to comply with the relevant provisions of the national Building Regulations.

9.6 Designers should refer to the relevant national Building Regulations and guidance for detailed conditions of use, particularly in respect of requirements for substrate fire performance, cavity closers and barriers, fire stopping of service penetrations and combustibility limitations for other materials and components used in the overall wall construction.

## 10 Proximity of flues and appliances

When installing the product in close proximity to certain flue pipes and/or heat-producing appliances, the relevant provisions of the national Building Regulations are applicable:

**England and Wales** — Approved Document J, sections 1 to 4

**Scotland** — Mandatory Standard 3.19, clauses 3.19.1<sup>(1)(2)</sup> to 3.19.9<sup>(1)(2)</sup>

(1) Technical Handbook (Domestic).

(2) Technical Handbook (Non-Domestic).

**Northern Ireland** — Technical Booklet L, sections 1 to 5.

## 11 Maintenance

As the product is confined within the wall cavity and has suitable durability (see section 12), maintenance is not required.

## 12 Durability



The product is unaffected by the normal conditions in a wall and is durable, rot proof, water resistant and sufficiently stable to remain effective as insulation for the life of the building.

## Installation

### 13 General

- 13.1 The Certificate holder will provide on-site demonstrations on request, to ensure correct installation from the outset.
- 13.2 Adequate supervision of the installation should be maintained and the Certificate holder must have right of access to the site to ensure correct installation.
- 13.3 It is recommended that the internal leaf is constructed ahead of the external leaf so that any mortar protruding into the cavity space from the back of the internal leaf can be cleaned off before installing the product. Boards must not be pushed into a completed cavity.
- 13.4 Vertical joints in the boards must be staggered and all joints tightly butted. Where protrusions occur in the cavity, the board should be carefully cut to fit.
- 13.5 If installation of the boards is terminated below the highest level of the wall, the top edge of the insulation must be protected by a cavity tray and alternate perpend joints raked out to provide adequate drainage of water from the tray.
- 13.6 Where required, door and window reveals should incorporate a suitable cavity barrier/closer (see Figures 5 and 6). It is recommended that BBA-approved cavity closers are used.
- 13.7 Where the Preformed Corner Panels are not used, wall corners must be constructed in accordance with section 14.17 and must incorporate a vertical dpc as shown in Figures 8 to 11.

### 14 Procedure

- 14.1 A section of the internal leaf is built in the conventional manner, with the first row of wall ties, at approximately 600 mm horizontal spacing, where the insulation is to begin. The wall ties should not be placed directly on the dpc. The first run of boards should commence at least 150 mm below the dpc level, to provide some edge insulation for the floor (see Figure 3). The Riser Panels can also be used to achieve this overlap.

Figure 3 Building in the first row of boards

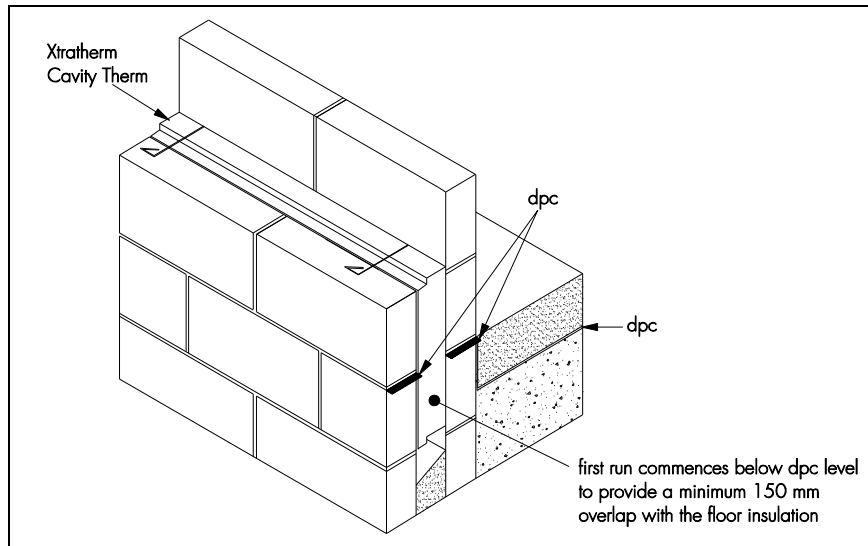

14.2 The internal leaf is then built up to a course above the next row of wall ties, which are placed at a vertical spacing of 450 mm vertically and not more than 900 mm horizontally (see BS EN 1996-1-2 : 2005). Excess mortar should be cleaned from the cavity face of the internal leaf.

14.3 Boards are placed between the upper and lower wall ties, behind the retaining clips, to form a closely butt-jointed run. It is essential that all wall ties slope downwards towards the external leaf, with the drip positioned in the centre of the boards pointing downwards to shed water away from the internal leaf.

14.4 The boards incorporate a specially designed rebated edging and are faced on one side with HIP sheet, with projecting tapered flutes. It is essential that the boards are positioned (orientated) according to the installation guidelines on the moulded HIP sheet (see Figure 1).

14.5 The corresponding edges of the two interlocking boards are cut with a sharp knife or fine-tooth saw to allow insertion of the wall ties so that they are sloping downwards to the outer leaf. Care must be taken to ensure that damage is minimised during this process.

14.6 The external leaf is built up to the same level as the boards, with its inner face in contact with the boards.

14.7 Where required, a suitable retaining-clip can be used to ensure boards are kept secure to the inner leaf.

14.8 Successive sections of wall, incorporating wall ties, are constructed and the boards installed, as work proceeds up to the required height.

14.9 Additional ties may be required to satisfy the structural requirements of BS EN 845-1 : 2013, BS EN 1996-1-1 : 2005, BS EN 1996-2 : 2006 and BS EN 1996-3 : 2006 to ensure adequate retention of boards or cut pieces.

14.10 All boards should be butted with vertical joints staggered. Insulation boards and wall ties should be staggered as construction proceeds and carried up to the highest level of wall, except where protected by a cavity tray.

### **Mortar droppings**

14.11 After each section of the wall leaf is built, excess mortar should be removed from the cavity face and mortar droppings cleaned from exposed edges of the installed board before installation of the next section. Use of a cavity board and cavity timber stop is recommended to protect installed board edges and to help keep the cavity clean as the following leaf is built (see Figure 4).

Figure 4 Use of cavity board when cleaning off excess mortar

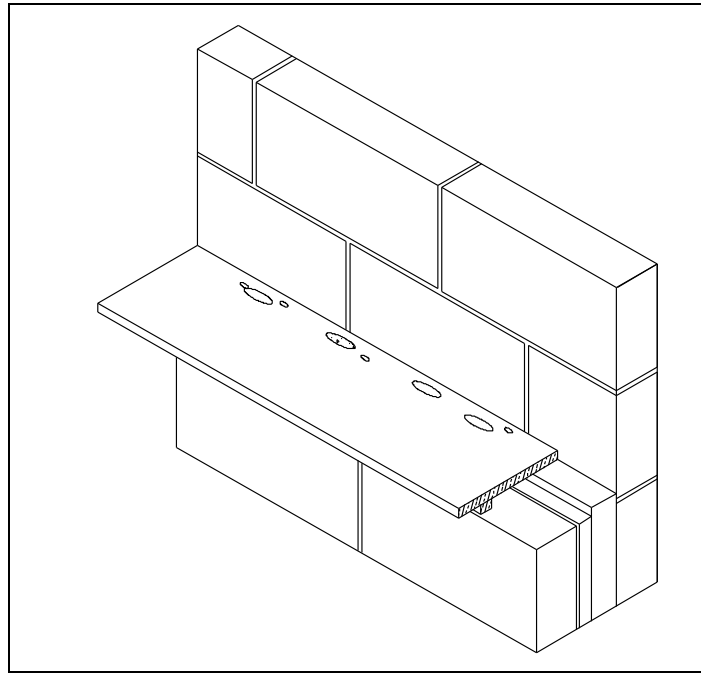

14.12 The boards can be cut using a sharp knife or fine-toothed saw to fit openings, eg around windows, doors and airbricks. It is essential that cut pieces completely fill the spaces for which they are intended and are adequately secured.

#### Wall openings

14.13 Where openings such as doors and windows are in close proximity, it is recommended that a continuous lintel or cavity tray is used. Individual lintels or cavity trays should have stopends and be adequately drained.

14.14 Where the boards are required to be fitted around openings the rebated edge should be trimmed using a sharp blade. It is important that the rebated edge is cut accurately so that a tight butt edge is formed at the opening interfaces. It must be ensured that proprietary cavity barriers/closers are correctly installed at window and door reveals (see Figures 5 and 6). Care should be taken when fitting the extra wall ties around openings in to the rebated edge.

Figure 5 Reveal detail with cavity closure (all dimensions in mm)

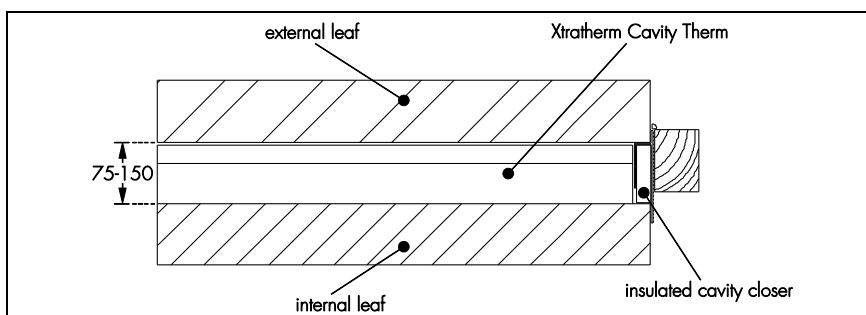
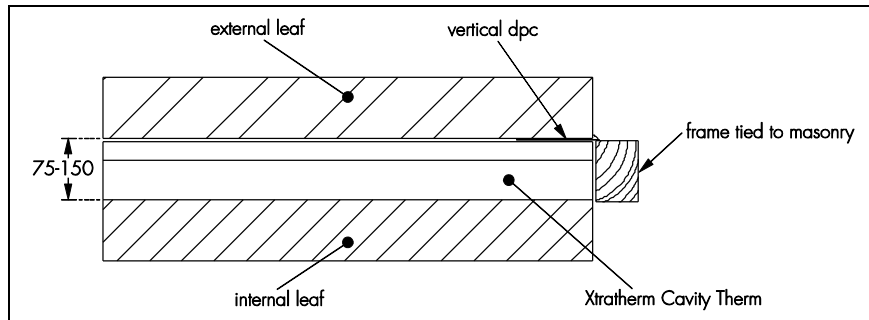
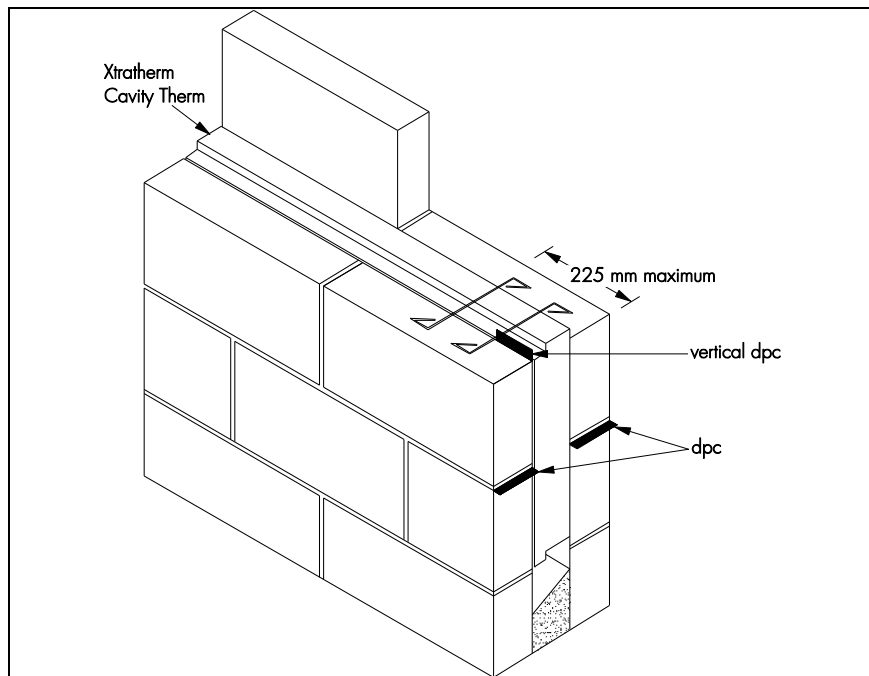

Figure 6 Reveal detail (all dimensions in mm)



14.15 Additional wall ties at 300 mm vertical centres within 225 mm of all openings are recommended in BS EN 1996-1-1 : 2005 and BS EN 1996-1-2 : 2005. For this product, this would involve piercing the boards and may introduce an unacceptable risk of water penetration. Therefore, it is recommended that an additional wall tie is included within 225 mm of the opening on each board course level to satisfy the structural requirements of the wall (see Figure 7).

Figure 7 Reveal detail with double ties



### Corners

14.16 The Preformed Corner Panels are recommended for use in forming both internal and external corner joints. Alternate corner pieces must be used to achieve staggered vertical joints.

14.17 Alternatively, corner details are formed by closely butting the boards, either by carefully removing the rebated edge to create square edges, or by cutting the boards at a 45° angle to create a mitred joint, so that all board interfaces are uninterrupted. All corner details incorporate a vertical dpc (see Figures 8 to 11).

Figure 8 Internal corner detail — butt joint

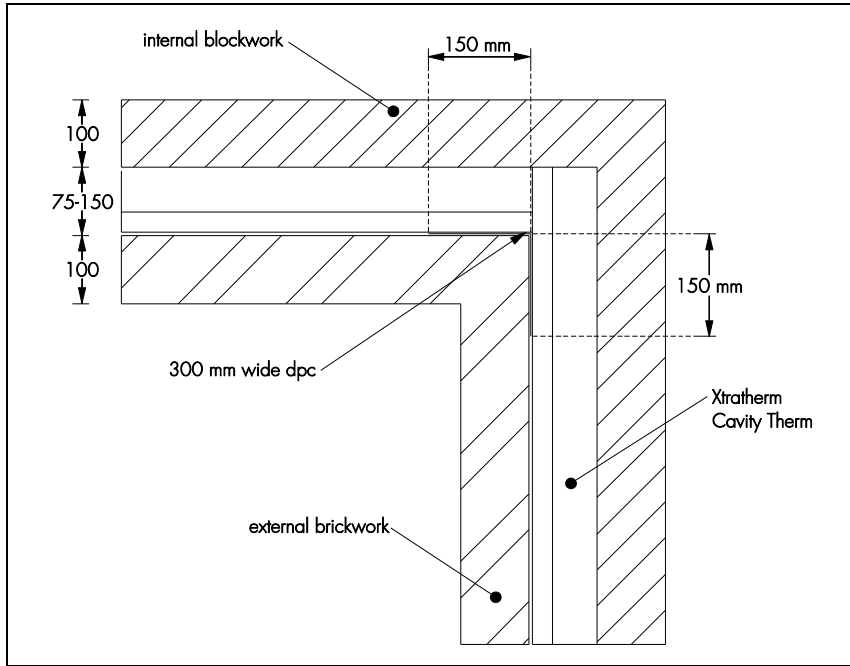

Figure 9 External corner detail — butt joint

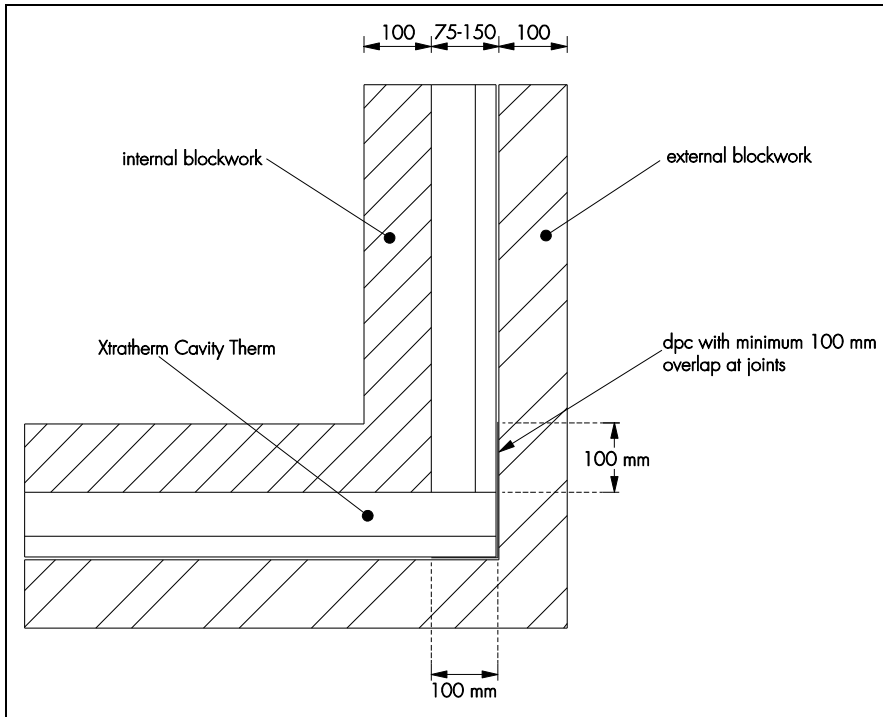

Figure 10 Internal corner detail — mitred

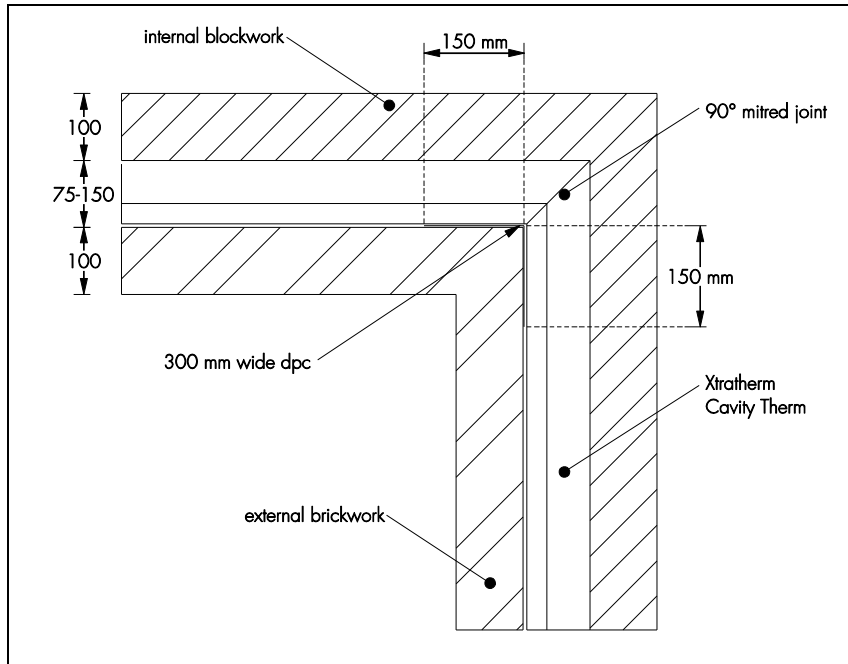
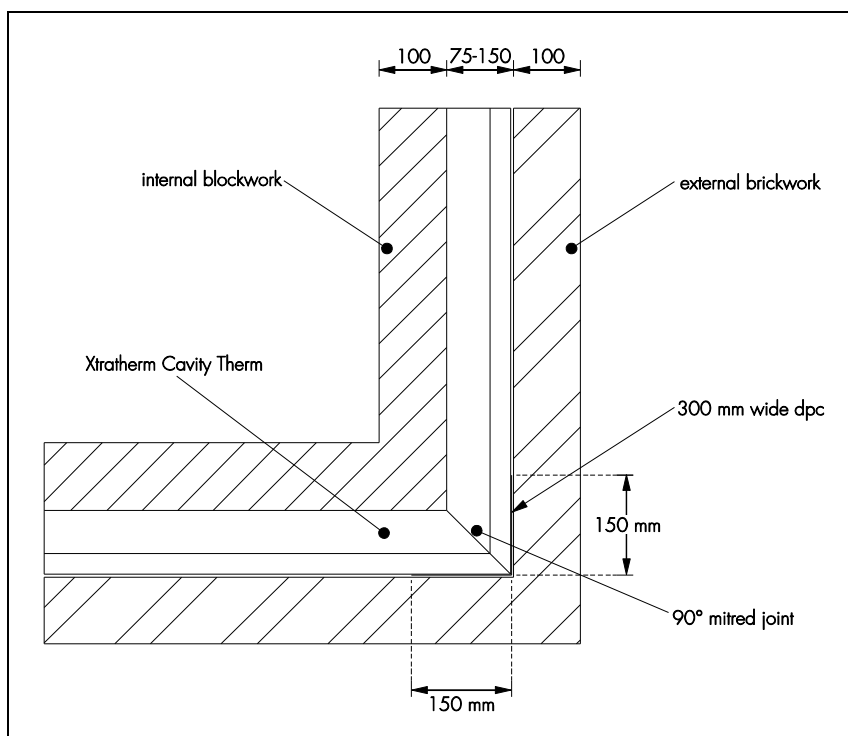

Figure 11 External corner detail — mitred



## Detailing

14.18 The Top Panels can be used to complete wall insulation heights when a full board is not required, reducing both the need to cut boards and wastage.

14.19 The accessories listed in section 1.6 can also be used to incorporate features such as cavity trays, service voids, meter boxes, and cables without the need to cut boards, while maintaining continuity of insulation. Further details on the use of these accessories can be obtained from the Certificate holder.



## Protection

14.20 Exposed areas of board should always be covered at the end of a day's work or in driving rain.

14.21 All building involving the product, particularly interrupted work, must conform to BS EN 1996-2 : 2006, Sections 3.2 *Acceptance, handling and storage of materials* and 3.6 *Curing and protective procedures during execution*.

## Technical Investigations

### 15 Tests

Results of tests were assessed to determine:

- resistance to rain penetration of an insulated cavity wall
- thermal conductivity
- dimensional accuracy
- dimensional stability under specific temperature and humidity conditions
- water absorption
- water vapour transmission.

### 16 Investigations

16.1 A calculation was undertaken to confirm the declared thermal conductivity ( $\lambda_D$ ).

16.2 A series of U value calculations were carried out.

16.3 A condensation risk analysis was carried out.

16.4 Existing data on toxicity, durability and properties in relation to fire were evaluated.

16.5 The manufacturing process was examined, including the methods adopted for quality control, and details were obtained of the quality and composition of the materials used.

## Bibliography

BS 5250 : 2011 *Code of practice for control of condensation in buildings*

BS 8000-3 : 2001 *Workmanship on building sites — Code of practice for masonry*

BS EN 845-1 : 2013 *Specification for ancillary components for masonry — Wall ties, tension straps, hangers and brackets*

BS EN 1996-1-1 : 2005 + A1 : 2012 *Eurocode 6 — Design of masonry structures — General rules for reinforced and unreinforced masonry structures*

NA to BS EN 1996-1-1 : 2005 + A1 : 2012 *UK National Annex to Eurocode 6 — Design of masonry structures — General rules for reinforced and unreinforced masonry structures*

BS EN 1996-1-2 : 2005 *Eurocode 6 — Design of masonry structures — General rules — Structural fire design*

NA to BS EN 1996-1-2 : 2005 *UK National Annex to Eurocode 6 — Design of masonry structures — General rules — Structural fire design*

BS EN 1996-2 : 2006 *Eurocode 6 — Design of masonry structures — Design considerations, selection of materials and execution of masonry*

NA to BS EN 1996-2 : 2006 *UK National Annex to Eurocode 6 — Design of masonry structures — Design considerations, selection of materials and execution of masonry*

BS EN 1996-3 : 2006 *Eurocode 6 — Design of masonry structures — Simplified calculation methods and simple rules for masonry structures*

NA to BS EN 1996-3 : 2006 *UK National Annex to Eurocode 6 — Design of masonry structures — Simplified calculation methods and simple rules for masonry structures*

BS EN 13165 : 2012 + A1 : 2015 *Thermal insulation products for buildings — Factory made rigid polyurethane foam (PU) products — Specification*

BS EN 13501-1 : 2018 *Fire classification of construction products and building elements — Classification using data from reaction to fire tests*

BS EN ISO 6946 : 2007 *Building components and building elements — Thermal resistance and thermal transmittance — Calculation method*

BS EN ISO 9001 : 2008 *Quality management systems — Requirements*

BS EN ISO 14001 : 2004 *Environmental management systems — Requirements with guidance for use*

PD 6697 : 2010 *Recommendations for the design of masonry structures to BS EN 1996-1-1 and BS EN 1996-2*

BRE Report (BR 262 : 2002) *Thermal insulation : avoiding risks*

BRE Report (BR 443 : 2006) *Conventions for U-value calculations*

### 17 Conditions

#### 17.1 This Certificate:

- relates only to the product/system that is named and described on the front page
- is issued only to the company, firm, organisation or person named on the front page – no other company, firm, organisation or person may hold or claim that this Certificate has been issued to them
- is valid only within the UK
- has to be read, considered and used as a whole document – it may be misleading and will be incomplete to be selective
- is copyright of the BBA
- is subject to English Law.

17.2 Publications, documents, specifications, legislation, regulations, standards and the like referenced in this Certificate are those that were current and/or deemed relevant by the BBA at the date of issue or reissue of this Certificate.

17.3 This Certificate will remain valid for an unlimited period provided that the product/system and its manufacture and/or fabrication, including all related and relevant parts and processes thereof:

- are maintained at or above the levels which have been assessed and found to be satisfactory by the BBA
- continue to be checked as and when deemed appropriate by the BBA under arrangements that it will determine
- are reviewed by the BBA as and when it considers appropriate.

17.4 The BBA has used due skill, care and diligence in preparing this Certificate, but no warranty is provided.

17.5 In issuing this Certificate the BBA is not responsible and is excluded from any liability to any company, firm, organisation or person, for any matters arising directly or indirectly from:

- the presence or absence of any patent, intellectual property or similar rights subsisting in the product/system or any other product/system
- the right of the Certificate holder to manufacture, supply, install, maintain or market the product/system
- actual installations of the product/system, including their nature, design, methods, performance, workmanship and maintenance
- any works and constructions in which the product/system is installed, including their nature, design, methods, performance, workmanship and maintenance
- any loss or damage, including personal injury, howsoever caused by the product/system, including its manufacture, supply, installation, use, maintenance and removal
- any claims by the manufacturer relating to CE marking.

17.6 Any information relating to the manufacture, supply, installation, use, maintenance and removal of this product/system which is contained or referred to in this Certificate is the minimum required to be met when the product/system is manufactured, supplied, installed, used, maintained and removed. It does not purport in any way to restate the requirements of the Health and Safety at Work etc. Act 1974, or of any other statutory, common law or other duty which may exist at the date of issue or reissue of this Certificate; nor is conformity with such information to be taken as satisfying the requirements of the 1974 Act or of any statutory, common law or other duty of care.